

HLP-003-FT

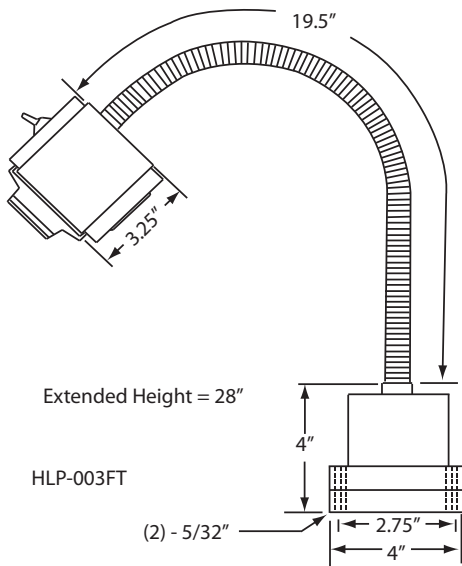

Technical Specifications



Safety Certifications	
CE Mark of Declaration, TÜV Rheinland	
Waterproof Certification	
IP 65 (Waterproof)	
Dimensions	
• Height	28.0"
• Diameter	3.25"
• Base Dimensions	4.5" diameter
• Beam	310°
• Net Weight	4.0 lbs
Material Specifications	
• Metal	Anodized aluminum
• Gaskets	Neoprene polymer located at head, boot, and switch
• Lens	Tempered borosilicate glass
Electrical Specifications	
• AC	120V
• Cycle	60 hz
• Transformer	Magnetic coil, located at base
• Amperage	Variable between .2 - .4
• Wattage	20, 50
• Kelvin (color temperature)	4100
• On/off switch	Toggle located on light head's back plate
Cord Specifications	
• Certification	SJT (oil resistant)
• Length	70.0"
• Plug	US 120V 2 prong
• Composition	14 gauge 2-conductor copper wiring, SJT (oil resistant) certified neoprene jacket
Options	
• Lens	Thick curved lens Magnetic base is included with this fixture
• Bulbs	HLP-70-H3-24, HLP-75-BI-24, HLP-100-BI-24

Products specifications are subject to change.



HALOGEN LIGHTING PRODUCTS CORPORATION™
 Telephone: 1-800-621-0001 • www.halogen-lighting.com