



**THE TOUGH GUY™**

# HLP-005-20



## Technical Specifications

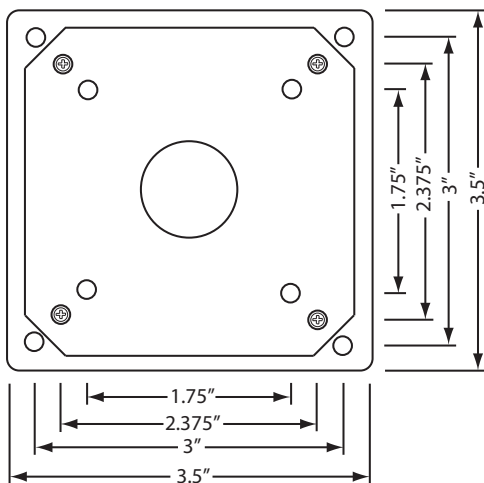
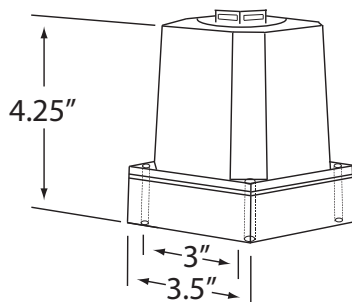
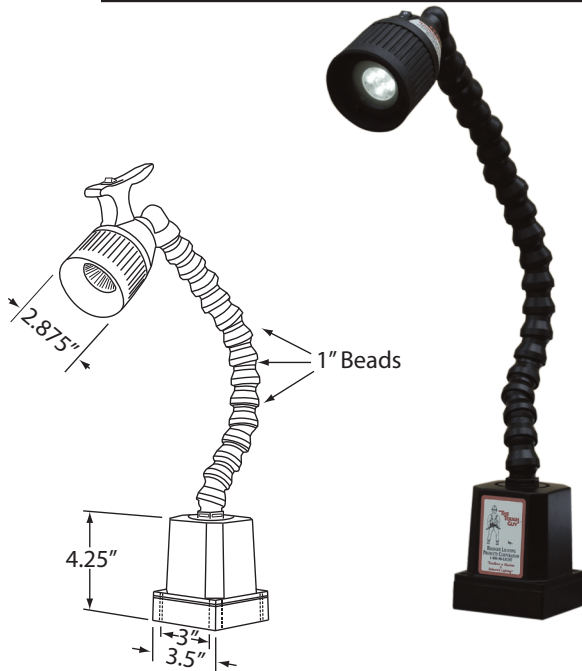

Safety Certifications	
CE Mark of Declaration, TÜV Rheinland	
Waterproof Certification	
IP 54 (Splashproof)	
Dimensions	
• Height	25"
• Diameter	2.875"
• Base Dimensions	3.5" X 3.5" , base flange is .25" with 5mm holes for mount
• Beam	310°
• Net Weight	4.5 lbs
Material Specifications	
• Metal	Anodized aluminum
• Gaskets	Neoprene polymer located at base
• Lens	Tempered borosilicate glass
Electrical Specifications	
• AC	120
• Cycle	60 hz
• Transformer	Magnetic coil, located in base
• Amperage	.3
• Wattage	35
• Kelvin (color temperature)	4100
• On/off switch	Rocker switch located on handle at head
Cord Specifications	
• Certification	SJT (oil resistant)
• Length	70"
• Plug	US 120V 3 prong
• Composition	14 gauge 3-conductor copper wiring, SJT (oil resistant) certified neoprene jacket
Options	
• Lens	Frosted glass
• Mounting Brackets	HLP-22-2000 (see below), HLP-23 (see below), HLP-24-005 (not shown) HLP-29-005 (not shown)
• Bulbs	HLP-35-MR16-12

Products specifications are subject to change.

### Optional Accessories

HLP-22-2000



HLP-23



**HALOGEN LIGHTING PRODUCTS CORPORATION™**

Telephone: 1-800-621-0001 • [www.halogen-lighting.com](http://www.halogen-lighting.com)