

Technical Specifications

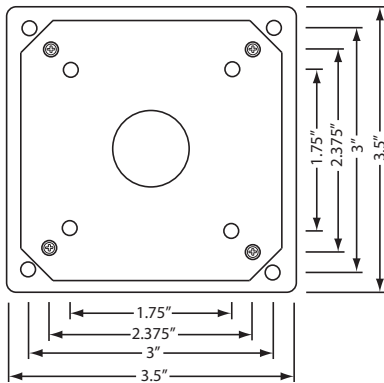
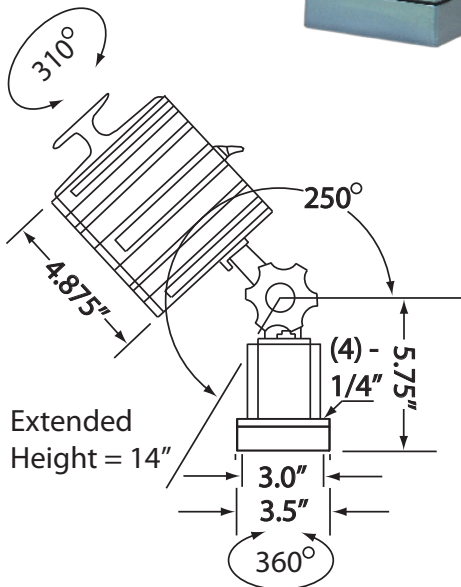
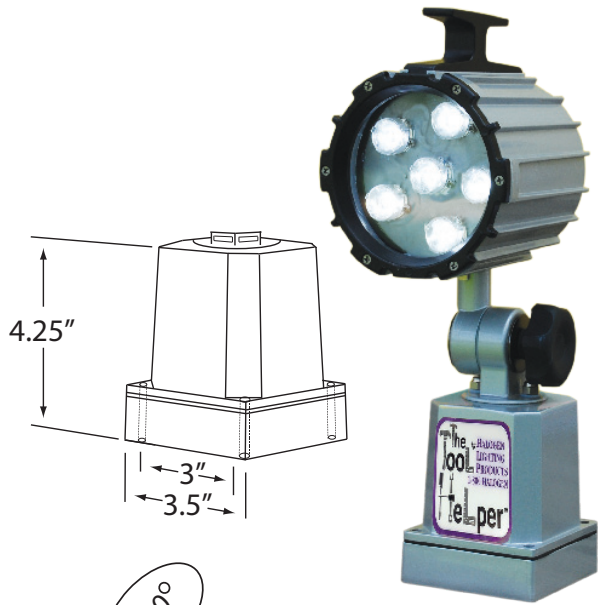

Safety Certifications	
CE Mark of Declaration, TÜV Rheinland	
Waterproof Certification	
IP 67 (Waterproof Under Pressure)	
Dimensions	
• Height	14.0"
• Diameter	4.875"
• Base Dimensions	3.5" X 3.5" , base flange is .25" with 5mm holes for mount
• Beam	310°
• Net Weight	3.5 lbs
Material Specifications	
• Metal	Anodized aluminum
• Gaskets	Neoprene polymer located at glass, base, and switch
• Lens	Tempered borosilicate glass
Electrical Specifications	
• AC	N/A
• DC	24VDC
• Cycle	N/A
• Transformer	Magnetic coil located in base. LED driver located in head
• Amperage	2.9
• Wattage	8
• Lux Rating	8,000 lx from 18"
• Kelvin (color temperature)	5,000
Cord Specifications	
• Certification	SJT (oil resistant)
• Length	6'
• Plug	US 120V 3 prong with ground
• Composition	14 gauge 3-conductor copper wiring, SJT (oil resistant) certified neoprene jacket
Accessories/Options	
• Lenses	Frosted glass
• Mounting Brackets	HLP-22-2000 (see below), HLP-23 (see below)

Product Specifications are subject to change

Optional Accessories:

